

A Guide to Incorporating Green Infrastructure into Roadway Projects in Santa Fe [DRAFT]

Why should you read this document? Santa Fe has begun incorporating green infrastructure practices to better manage stormwater from their city projects. This document provides the city with information for city departments/staff to consider as they incorporate green infrastructure practices specifically into roadway improvement projects. It is a basic primer, and is not intended to be a design manual. This document will also be available for public viewing, and may be used by Santa Fe as part of informational packets for local developers and engineers.

Who should read this document? City departments/staff and private developers/engineers involved in road redesign and reconstruction projects, redevelopment and urban renewal/revitalization, streetscape design, and maintenance of roadways and landscaping.

Table of Contents

1. Introduction	2
2. Considering Green Infrastructure within the Broader Project Development Process	4
2.1 Incorporating Green Infrastructure into City Projects	5
3. Green Infrastructure Practices	6
3.1 Practices for Rights of Way	6
3.1.1 Green Infrastructure Practice Sheet: Bioretention System	8
3.1.2 Green Infrastructure Practice Sheet: Tree Trench	13
3.1.3 Green Infrastructure Practice Sheet: Permeable Pavement	18
3.1.4 Green Infrastructure Practice Sheet: Bioswales	23
3.1.5 Green Infrastructure Practice Sheet: Impervious Pavement Reduction	26
4. General Design Considerations	31
5. Maintenance of Green Infrastructure Practices	32
6. Permitting/Regulatory Considerations	34
7. Example Design Concepts for Santa Fe Sites	35
8. References	36

1. Introduction

Green infrastructure is a stormwater management technique designed to mimic natural site hydrology and promote absorption, filtration, evapotranspiration or reuse of stormwater. These practices provide an effective and efficient mechanism to improve water quality, provide groundwater recharge, and reduce potable water needs for irrigation. They also offer the benefit of greening and beautifying roadways, parking lots, patios or sidewalks. Unlike pipes and other gray infrastructure, green infrastructure practices often include visible above ground plants, providing the opportunity for Santa Fe residents and visitors to view the city's water quantity and quality improvements firsthand.

Green infrastructure practices manage stormwater through conveyance and filtration systems, while removing nutrients and other pollutants through soils and plants. In addition to stormwater management, these practices provide a host of other benefits:

- Reduction in urban heat island effect through the replacement of impervious surfaces with pervious pavement options, addition of greenspace, and increased tree canopy.
- Increased groundwater recharge through infiltration. This is particularly appealing for Santa Fe, where drought is a major concern.
- Improved public health and air quality by providing green spaces and new habitat for native species.

The Benefits of Green Infrastructure Far Outweigh those of Gray Infrastructure

- Water quality
- Reduced heat island effect
- Groundwater recharge
- Ecological Habitat
- Public Green Space
- Public Health
- Air Quality



Figure 1. Acequia Underpass Bioretention

This document focuses specifically on green infrastructure practices in roadway settings. These include collector roads and arterial roads, as identified by the *Santa Fe Metropolitan Transportation Plan (2015-2040)*¹, as well as roundabouts, curb and gutter roads, pedestrian walkways/sidewalks, bike paths, and complete streets.

Types of Public Roadways

Public road classifications are defined by the state and federal highway transportation agencies. The Santa Fe MPO Metropolitan Transportation Plan 2015-2040 presents the approved classification designations for specific Santa Fe roads. The general categories of roads are:

Local Roads: Roads that carry no through traffic movement and are used to provide access to adjacent land.

Collector Roads: Roads that collect traffic from local roads and connect them to arterial roads. The Collectors typically include a blend of mobility and accessibility characteristics. They are categorized in Santa Fe as Urban, Rural Major and Rural Minor collector roads.

Arterial Roads: Roads in a state that provide high mobility, are used for throughput of travel, and have limited or controlled access. They are categorized in Santa Fe as Principal or Minor arterial roads.

Sources:

NMDOT Functional Classification Guidance Manual (October 2013, Revised February 2014)

http://dot.state.nm.us/content/dam/nmdot/planning/NMDOT_FC_Guide.pdf

Santa Fe MPO Metropolitan Transportation Plan 2015-2040 (Adopted August 27, 2015)

http://santafemopo.org/wp-content/uploads/2015/09/Santa-Fe-MPO-MTP_FINAL_Electronic.pdf

¹ Santa Fe Metropolitan Transportation Plan (2015-2040): <http://santafemopo.org/mtp/metropolitan-transportation-plan-2015-2040/>

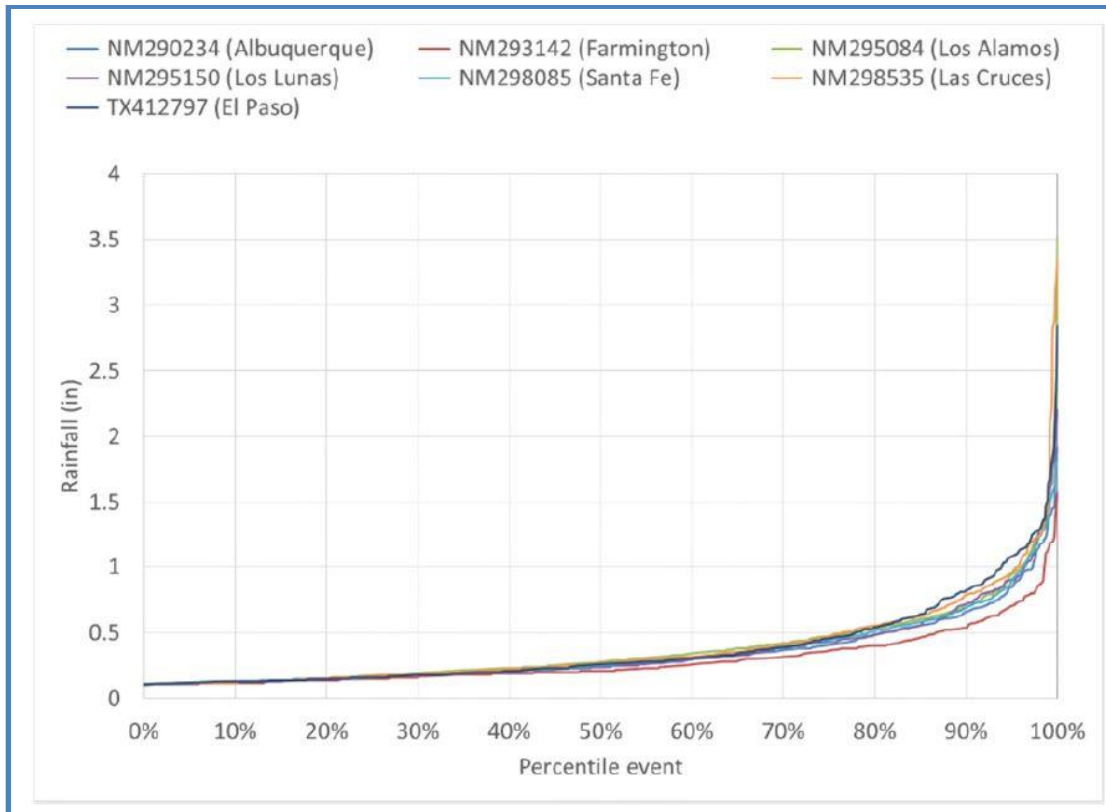

Figure 2. Percentile rainfall analysis for Santa Fe and other New Mexico locations (20). In Santa Fe, 90% of rainfall events produce less than 0.68 inches of rain. It is vital to get that water back in the ground as soon as possible to replenish the aquifers and support the natural ecosystem.

2. Considering Green Infrastructure within the Broader Project Development Process

As in any urban area, Santa Fe has a large network of impervious roadways that generate significant runoff and reduce infiltration of water into the ground. Runoff picks up and transports pollutants from the road surface into nearby waterways, generates flows that cause erosion, and contributes to flooding. As such, implementing green infrastructure practices in and along roadways offers opportunities to infiltrate, treat, and reuse stormwater runoff at the source. Roadways also require regular maintenance and improvements; therefore, considering green infrastructure implementation during the early design phase is critical to ultimately constructing roadways that are functional and sustainable over the long term. Further, Santa Fe can incorporate green infrastructure into improvements the city plans for existing roadway projects, including streetscape improvements, safety upgrades, projects to comply with the Americans with Disabilities Act like curb ramps and pedestrian crossings, or road repairs and other utility work. If the city is prepared with a list of potential green infrastructure projects, it can more easily implement stormwater controls alongside planned redevelopment, road improvement or pathway projects during the concept and design phases. This not only reduces costs for construction and labor, but also time and costs associated with roadway and

sidewalk closures, when compared to stand alone projects. This can result in a decreased impact to the community due to the hassle of detours and other inconveniences.

In addition, green infrastructure practices that are part of roadway projects may be eligible for government-sponsored clean water or transportation grant and loan program funding. For example, if green infrastructure designs are integrated into roadway projects at the concept or design phase of a roadway project, costs for excavation and landscaping can be covered by grant or loan funding if the project is contributing to water resource protection goals, such as reduced nutrient or pollutant loading to nearby waterways.

Incorporating green infrastructure into long-term planning may also allow Santa Fe to leverage public-private partnerships and take advantage of mutually beneficial opportunities to install these practices on private properties adjacent to city ROWs. Public-private partnerships can offer opportunities, not only for green infrastructure implementation, but also for help with maintenance of public and private assets.

2.1 Incorporating Green Infrastructure into City Projects

The process below is adapted from the Los Alamos National Laboratory Low Impact Development (LID) Standards/Plan and offers a project process for implementing green infrastructure at the definition or concept, proposal, and design phases of infrastructure projects (1). Santa Fe can consider these steps to integrate these controls through different project phases and may want to create a similar checklist representing their own process.

Project Definition Phase

- ✓ Incorporate green infrastructure into project scopes and budgets.
- ✓ Identify who will maintain and monitor green infrastructure after project completion.

Project Proposal Phase

- ✓ Obtain site information showing boundary and existing improvements within project area.
- ✓ Identify general topography and drainage pattern.
- ✓ Identify existing utilities alignments.
- ✓ Identify access and environmental needs.
- ✓ Identify the urban-rural design quality for LID and green infrastructure improvements to be used in the project design.
- ✓ Add expectation for green infrastructure into design guidance in proposal request.
- ✓ Confirm that costs and environmental benefits for green infrastructure improvements are reflected in the bids and final contract.

Want to know more?

The Los Alamos National Laboratory LID Plan and Standards provide a great deal of information on the benefits of implementing LID and green infrastructure in the region, detailed design specifications, maintenance considerations, and graphical representations of applicable green infrastructure practices for the region.

Available Online: [INSERT LINK](#)

Project Design Phase

- ✓ During plan concept development, conduct site analysis for potential green infrastructure improvements.
- ✓ Ensure that a subject matter expert (SME) who is familiar with green infrastructure is involved in reviews and approvals, and participates in project development.
- ✓ Identify hold points for inspection and approvals during construction.
- ✓ Obtain topographical survey of site at minimum 1' contours.
- ✓ Confirm existing conditions.
- ✓ Conduct soils analysis and percolation rate tests as required for proposed design.
- ✓ Analyze contributing surface runoff and potential storm water capture area.
- ✓ Confirm how existing storm water structures or improvements will affect or be affected by the proposed project.
- ✓ Confirm during 30/60/90/100% project reviews that green infrastructure are incorporated in the design, cost, and environmental benefits estimates.

3. Green Infrastructure Practices

Implementing green infrastructure on roadways, roadsides, or public rights of way (ROWs) allows for

Please Share!

These GI Practice Sheets presented in Section 3.1 can be excerpted as concise 'cut sheets' to convey this information easily to other staff, contractors, engineers or the public.

better stormwater management through engineered practices that mimic natural systems. Green infrastructure practices control and treat stormwater through infiltration, absorption, storage, and filtration. The green infrastructure practices described in this section are specific to ROW implementation and focus on practices that promote infiltration and absorption of runoff and filtration of pollutants to improve water quality. These practices are summarized briefly below and described in more detail in the subsequent Green Infrastructure Practice Sheets. Further, Table 1 illustrates potential ROW locations for each practice; however, designs should be site-specific and consider various suitability factors like topography and slope, infiltration rate, drainage area,

locations of utilities, property ownership, driveway access needs and curb cuts, etc. Section 4 includes further discussion on general design considerations.

3.1 Practices for Rights of Way

Bioretention. A shallow landscape depression sited at a low point to collect, treat and infiltrate stormwater. Typically designed for water quality treatment; however, with adequate space it can provide minor flood storage.

Tree Trench. A double-duty street tree. From the surface, it appears to be an ordinary tree pit. Underneath, engineered soils, gravel bedding and underdrain pipes promote healthier tree growth with the added benefits of nutrient uptake, pollutant removal, and minor flood storage.

Permeable Pavement. An alternative to traditional pavement which allows infiltration through interstitial void space to reduce runoff and trap suspended solids. Typically designed to reduce runoff volumes, however in the appropriate setting, it can include an extended gravel reservoir to provide additional minor flood storage. In addition, permeable pavement can be used as a friction course on

existing pavement. Permeable pavement can also reduce road noise, splash and spray, and hydroplaning, as well as promote traffic calming in certain installations.

Bioswale. A linear landscape element widely used along horizontally restricted ROWs. Designed for water quality treatment. A perforated underdrain with connections to the larger drainage network can increase safety by reducing overflows.

Pavement Reduction. The most practical, simple, and cost-effective solution is to identify and remove unnecessary pavement. This could be combined with a ‘road diet’ aimed at improving roadway safety or implemented during the design phase of new construction projects. Replacement surface treatment may include: hydroseeding, artificial turf, planting beds, washed gravel, permeable pavement/pavers, or vegetated stormwater management practices.

Table 1. ROW Locations for Green Infrastructure Practices

Applicable ROW Location	Green Infrastructure Practice				
	Bioretention	Tree trench/tree pit	Permeable pavement	Bioswale	Pavement Reduction
Roadway (medians)	✓	✓	✓	✓	✓
Roundabouts	✓	✓			✓
Rights-of-way/hell strips	✓	✓		✓	✓
Curb and gutter roadways	✓	✓		✓	✓
Pedestrian, bike, and multi-use paths	✓	✓	✓	✓	✓
'Complete' streets for multi-modal transportation	✓	✓		✓	✓
Parking lot islands/edges	✓	✓	✓	✓	✓
Cul-de-sacs	✓	✓	✓		✓
Courtyards/patios	✓	✓	✓		✓

3.1.1 Green Infrastructure Practice Sheet: Bioretention System

A bioretention system is a shallow landscape depression sited at a low point and designed to collect and treat (and sometimes infiltrate) stormwater runoff (1, 2). It serves as both an aesthetically pleasing, sustainable landscaping element within a roadway setting and a stormwater infrastructure element, and it provides multiple benefits to the surrounding human and natural environment. Most importantly, bioretention systems provide an opportunity to retain or infiltrate stormwater and recharge the aquifer, reduce pollutants delivered to receiving waters, and reduce the burden of landscaping on potable water sources for irrigation. Bioretention practices are typically designed for water quality treatment through filtration, biological uptake and microbial activity (1, 2, 9). With adequate space, they can provide some flood storage (9). They can also be designed for double duty as roadway bump-outs that provide traffic calming and improve pedestrian safety by reducing the length of cross-walks.

Benefits

- ✓ Recharges groundwater.
- ✓ Prevents surface ponding during small rain events, but should include an overflow mechanism to accommodate heavy rainfall events.
- ✓ Reduces pollutants/improves water quality.
- ✓ Improves aesthetics.
- ✓ Increases habitat value.
- ✓ Provides shade/reduces urban heat island effects.
- ✓ Provides carbon sequestration.
- ✓ Improves air quality.
- ✓ Reduces long term irrigation needs/potable water dependency.

Roadway/Transportation Applications

- ✓ Roadway medians
- ✓ Roundabouts
- ✓ Rights-of-way/vegetated roadway edge
- ✓ Curb and gutter roadways
- ✓ Pedestrian sidewalks/bike/multi-use paths
- ✓ 'Complete' streets for multi-modal transportation
- ✓ Parking lot islands/edges
- ✓ Cul-de-sacs
- ✓ Courtyards/patios

Design considerations

Physical Site Characteristics

- ✓ Challenging on steep slopes. Incorporate diversion berms, check dams, or terraces so bottom is relatively flat sloped (1-5%).
- ✓ Consider if the site has shallow bedrock or high groundwater. Use in areas where porous underground material (i.e. tuff) is at least 18" below the bottom of the practice (1). Avoid groundwater contamination by separating the practice from the groundwater table. A

separation distance of 2 feet is recommended between the bottom of the excavated bioretention area and the seasonally high ground water table.

- ✓ Consider potential groundwater contamination. Consider using other solutions for drainage areas with gas stations, chemical storage areas, and other areas that could potentially have hazardous spills.
- ✓ Consider the drainage area. Bioretention can serve a highly impervious area less than 2 acres in size, and the surface area of the practice should be approximately 3-6% of the contributing drainage area. The sediment trap or forebay should be sized to contain 5 % of the total detention volume.

Design Elements

- ✓ Top elevation of sediment trap interior wall should be a minimum of 4" below gutter inlet elevation.
- ✓ Interior wall at planting area should be a maximum 4" below gutter inlet elevation.
- ✓ Consider amount of nearby pedestrian activity and provide walkways or bridges across the practice if needed to allow for unimpeded movement.
- ✓ Design to avoid conflicts to subsurface utilities.

Soils

- ✓ Soils should have a suitable infiltration rate (>0.5 inches/hour). If the infiltration rate is low (<0.5 inches/hour) consider amending soils, including an underdrain to allow overflow, or installing a minimum 12" sand layer under the basin.
- ✓ Reduce soil compaction by either mixing with soil amendments or replacing with structural soils or other suitable soil media.
- ✓ Soils should be suitable to sustain the selected plantings. In general, tree soils require more moisture holding capacity than soils that support herbaceous plants or xeriscape.

Vegetation

- ✓ Vegetation should be drought tolerant, able to withstand periodic inundation, and salt tolerant.
- ✓ Planting zone should be stabilized with 3" depth of shredded wood or rock mulch (crushed rock, pea gravel, or small stones).

(1, 3, 4, 6, 9, 13, 18)

Pretreatment

- Sediment forebay/sediment trap, bioswale, gravel or stone diaphragm.

Construction considerations

- Where relying on existing soils for infiltration, do not over-compact basin soils. Compaction can reduce infiltration rates by increasing bulk density of the soil.
- Identify appropriate materials and hold points for inspection and approval. Ensure maintenance access is included in the design and construction of the practice.(1, 13)

Maintenance

- Inspect for the following at least annually, and repair as needed:
 - Adequate perennial vegetation coverage; erosion; degradation of check dams and others structures; debris, trash and sediment accumulations; and to ensure runoff flows through the full length of the practice.
- Prune trees and shrubs, remove dead vegetation, and remove plantings as needed to avoid overcrowding.
- Check for and remove invasive species.
- Do not mow vegetation.
- Remove sediment from the forebay regularly.
- Remove trash and dead vegetation regularly.
- Stabilize any areas to prevent erosion.
- If soils become compacted, turn or till soils.(1)

Planning level costs

- Low cost/acre for rural applications (\$-\$\$). Can be moderate to high for urban locations (\$\$\$).
(1)



Example of a Bioretention Basin, Acequia Underpass (Photo Credit: Leroy Pacheco, City of Santa Fe)

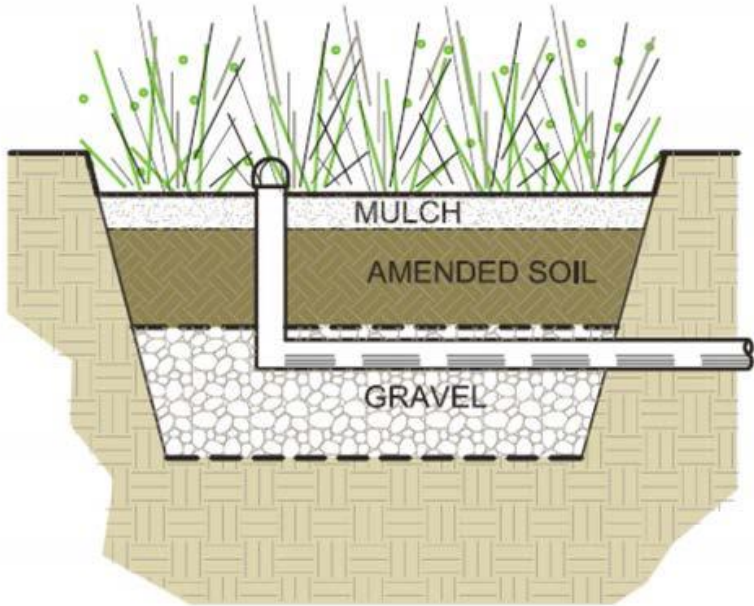

Diagram of bioretention system with under-drain and infiltration into the subsurface (2)



A small bioretention system was constructed in 2016 by retrofitting an existing vacant curb median at the intersection of Espinacitas and Hopewell streets in Santa Fe. (Photo credit: Santa Fe Watershed Association).



West Alameda rain garden, near Sicomoro Street, in Santa Fe, NM (Photo credit: Santa Fe Watershed Association).

3.1.2 Green Infrastructure Practice Sheet: Tree Trench

A tree trench is a type of infiltration trench containing one or multiple trees, which is located within street right-of-way (ROW) between the street and the sidewalk (2, 7). It combines the benefits of a street tree with the efficiency of a stormwater infrastructure element, providing multiple benefits to the surrounding human and natural environment using only minimal surface space. Most importantly, it provides an opportunity to infiltrate and evapotranspire stormwater and recharge the aquifer, reduce pollutants delivered to receiving waters, and reduce the burden that landscaping can have on potable water sources for irrigation. Tree trenches are typically designed for water quality treatment and to promote healthier tree growth (2, 7). With adequate space, the practice can provide modest flood reduction benefit (9). In a ROW, stormwater runoff enters the practice through the catch basins, passes through crushed stone, is conveyed through an underdrain to one or more tree plantings, fills void space, and exits back through the catch basin (7).

Benefits

- ✓ Recharges groundwater.
- ✓ Reduces pollutants/improves water quality.
- ✓ Improves aesthetics.
- ✓ Increases habitat value.
- ✓ Provides shade/reduces urban heat island effects.
- ✓ Provides carbon sequestration.
- ✓ Improves air quality.
- ✓ Reduces long term irrigation needs/potable water dependency.
- ✓ Uses minimal surface space.

Roadway/Transportation Application

- ✓ Roadway medians
- ✓ Roundabouts
- ✓ Rights-of-way/vegetated roadway edge
- ✓ Curb and gutter roadways
- ✓ Pedestrian/bike/multi-use paths
- ✓ 'Complete' streets for multi-modal transportation
- ✓ Parking lot islands/edges
- ✓ Cul-de-sacs
- ✓ Courtyards/patios

Design Considerations

Physical Site Characteristics

- ✓ Challenging on steep slopes. If slopes are greater than 4 or 5%, then consider using a terraced approach.

- ✓ Consider if the site has shallow bedrock or high groundwater. A separation distance of 3 feet is recommended between the bottom of the practice and the seasonally high ground water table.

Design Elements

- ✓ Center the tree trench approximately 4-6 feet behind the back of curb to preserve the step-out zone on the curb side of the trees and the sidewalk on the other.
- ✓ Typical size of the soil media is 3 to 4 feet in width by 6-8 feet in length and up to 4 feet in depth, and when combined with a stone storage reservoir, cobbles, or porous rubber, typically provides adequate space for tree roots to grow and expand. Proper sizing will help prevent sidewalk upheaval from root growth.
- ✓ Permeable pavement is an option above the tree trench to intercept additional stormwater and help to provide oxygen to the roots of the tree.
- ✓ Tree trench sections can be constructed back to back for any length desired. However, an inlet and water control structure is recommended for every three trees.

Soils

- ✓ Suitable soil infiltration rates required to prevent tree roots from drowning, or overflow mechanism needed for larger rain events.

Vegetation

- ✓ Aboveground or subsurface utilities can provide challenges. Select trees with maximum growth potential less than the height of the utility (usually about 30 ft). Factor in enough space so underground utilities are protected from roots and water.
- ✓ Tree selection should be well suited to tree trench size and distance to adjacent structures, to avoid conflicts or restrictions on root growth.
- ✓ Use xeriscaping. Xeriscaping uses vegetation compatible with the New Mexico environment and offers cooling and habitat, while using less water than other vegetation types.
- ✓ Water for trees should be applied as efficiently as possible and only when necessary. Drip, bubbler, and micro-spray systems or soaker hoses are appropriate for trees.

(1, 2, 4, 5, 6)

Pretreatment

- Pretreatment filter designed with media (e.g., pea gravel). (7)

Construction considerations

- Do not over-compact soil during the delivery of plants to the planting locations, digging of planting holes and installing plants. Compaction can reduce infiltration rates by increasing bulk density of the soil.
- Examine the surface grades and soil conditions; only plant when weather and soil conditions are suitable for planting the specified materials in accordance with locally accepted practices.
- When applicable, plant trees before other plants are installed. (13)

Maintenance

- Remove sediment and trash from the catch basin, and remove trash and dead vegetation from tree trench regularly.
- Upkeep of vegetation includes occasional weeding, pruning, removal of invasive species/pests.
- If mulch is used, check to see if it needs to be replaced.
- Turn or till soil if compaction occurs.
- Check for signs of erosion and improper root growth.
- Check that the irrigation system is functioning properly, and adjusting automatic irrigation systems as the seasons change. (4, 5, 7)
- Inspect underdrain for obstructions.

Planning level costs

- Moderate cost/acre (\$\$). (17)

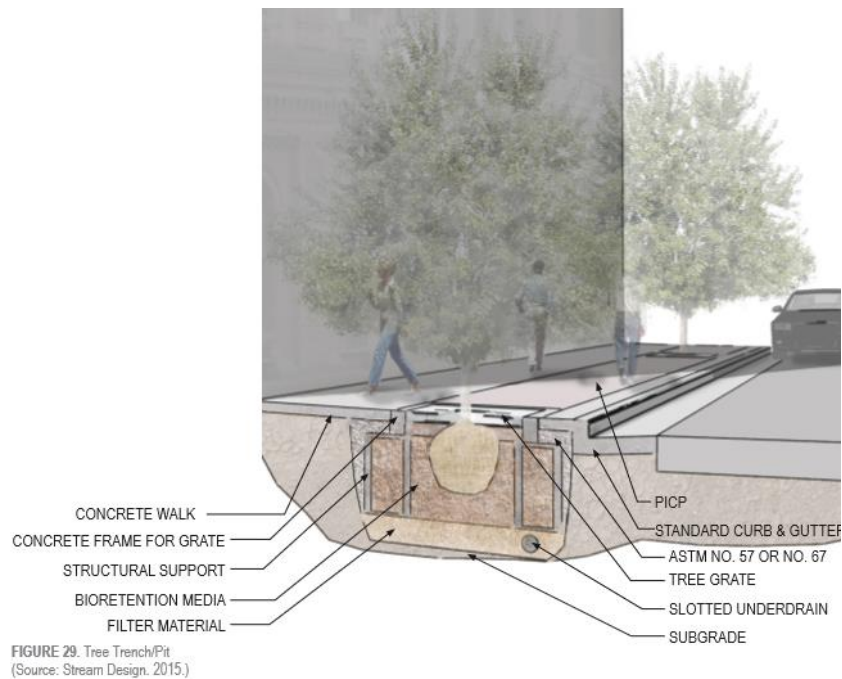

Tree trench design (6)

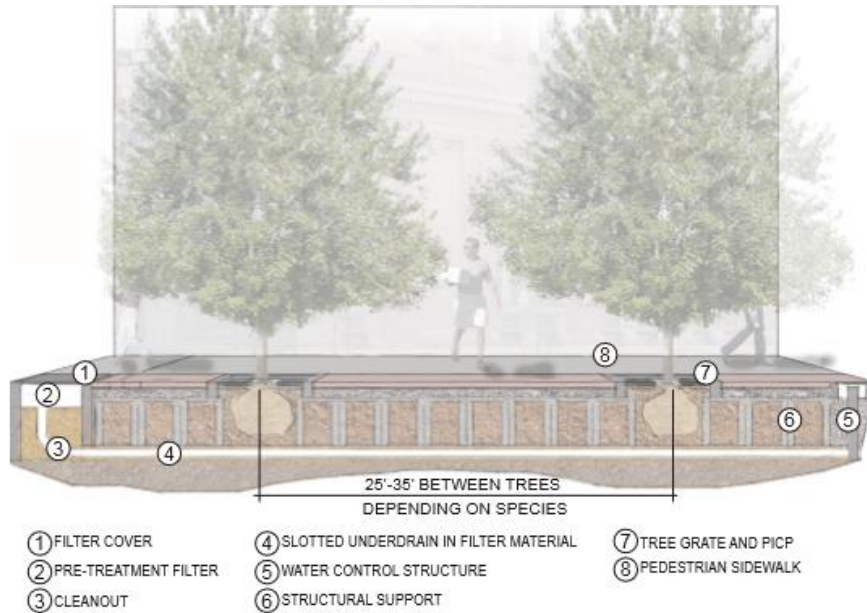

FIGURE 30 . Tree Trench/Pit Profile View (Source: Stream Design, 2015.)

Tree trench design (6)



Curb inlets to tree trench pavilions in parking lot in Albuquerque, NM (2)

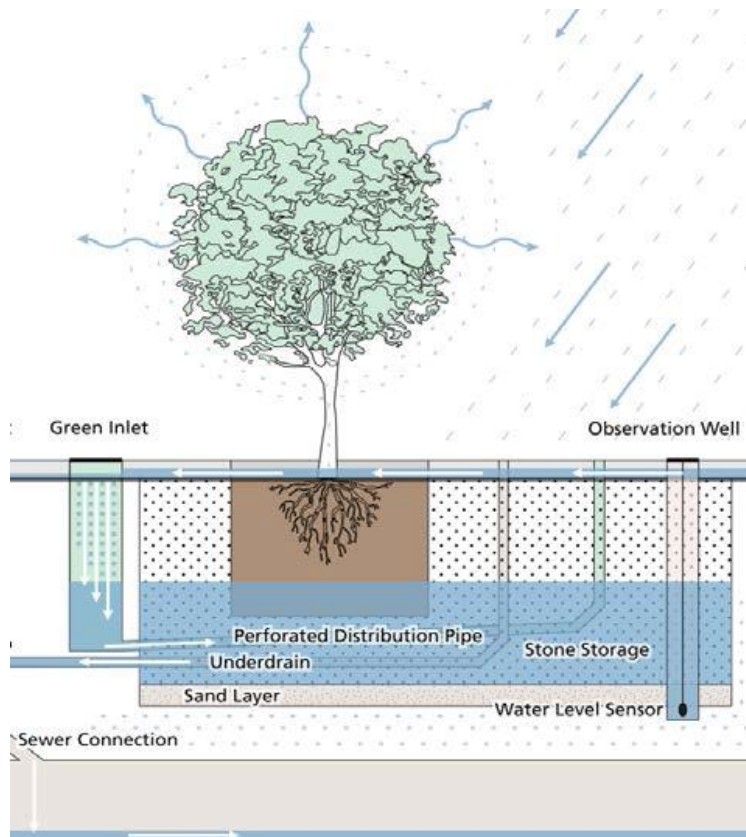

Diagram of tree trench (2)

3.1.3 Green Infrastructure Practice Sheet: Permeable Pavement

Permeable pavement is any paving material that allows rainwater and snowmelt to infiltrate where it falls, including permeable pavers, porous asphalt, pervious concrete, and supported gravel/aggregate soils (1, 2, 13). It provides the benefits of a stormwater infrastructure element without losing the functionality of traditional pavement. Most importantly, it provides an opportunity to infiltrate/retain stormwater, recharge the aquifer and reduce pollutants delivered to receiving waters. The porous paving materials are underlain by a designed sub-base that allows the percolation of stormwater through the sub-strata for temporary storage and/or infiltration (1, 13). Examples include porous asphalt, permeable friction course, pervious concrete, pavers, permeable interlocking concrete pavement, and concrete grid pavement.

Benefits

- ✓ Recharges groundwater.
- ✓ Reduces pollutants/improves water quality.
- ✓ Prevents surface ponding during small rain events.
- ✓ Reduces runoff temperatures.
- ✓ Uses minimal surface space.
- ✓ Reduces road noise.
- ✓ Reduces roadway splash and spray, and reduces pollutant wash-off from auto undercarriages.
- ✓ Improves safety by reducing hydroplaning.

Roadway/Transportation Applications

- ✓ Roadways
- ✓ Pedestrian/bike/multi-use paths
- ✓ Parking lots
- ✓ Cul-de-sacs
- ✓ Courtyards/patios
- ✓ Areas with light traffic within commercial and residential sites

Design considerations

Physical Site Characteristics

- ✓ Permeable pavement is only recommended for gentle slopes (< 5%). The bottom of the infiltration bed should be flat, so consider terracing if needed.
- ✓ Consider potential groundwater contamination and depth to water table. Consider other solutions for drainage areas with gas stations, chemical storage areas, and other areas that could potentially have hazardous spills.
- ✓ Appropriate for use in light traffic areas where heavy loads are limited, due to the lower resistance to stress than traditional pavement.

Design Elements

- ✓ All permeable pavements have a similar structure, consisting of a surface pavement layer, an underlying stone aggregate reservoir layer, optional underdrains and geotextile over uncompacted soil subgrade, though details may vary; Design per manufacturer recommendation.
- ✓ Snow management should be considered. Avoid applying sand for traction since this can clog the surface material. Do not use permeable pavement as a storage area for plowed snow.
- ✓ Permeable pavement is appropriate for infiltrating the precipitation that falls directly on it. Directing additional accumulated runoff from adjacent impervious areas can carry sediment and organics that can clog the system and reduce infiltration capacity, and is not recommended. However, if this approach is taken, consider runoff ratios and the type of source areas in the drainage area before directing the discharges to the permeable pavement. The runoff directed to the permeable pavement should be pretreated to remove sediments and other pollutants that can potentially clog the system. For installations adjacent to traditional pavement, consider elevating the permeable areas to avoid run-on.
- ✓ Run-off from adjacent vegetated areas can carry sediment. Stabilize adjacent vegetated areas to limit the transport of sediment, which could contribute to clogging of the permeable pavement.

Soils

- ✓ Suitable soil infiltration rates are required, or overflow mechanism needed for larger rain events. Amend or replace soils to improve permeability. For storms in excess of the infiltration/storage capabilities of the pavement the design should ensure that the excess runoff does not negatively impact downstream water bodies.
- ✓ Consider designs to address clay soils with high shrink-swell capacity. Increase the subbase depth and/or add geogrids to provide additional support.

(1, 2, 9, 11, 13, 19)

Pretreatment

- N/A

Construction considerations

- Do not over-compact basin soils, where relying on existing soils for infiltration. Compaction can reduce infiltration rates by increasing bulk density of the soil.
- Ensure that subgrades are properly installed to prevent the finish surface from becoming uneven over time.
- Identify appropriate materials and hold points for inspection and approval. Failure to follow the recommendations will likely cause premature structural failure.

(1)

Maintenance

- Regular sweeping or vacuuming with a vacuum sweeper is required to ensure that clogging does not occur.
- Inspect for proper drainage and to identify any deterioration, cracks and settling.
- Inspect adjacent areas for sources of sediment like erosion of uphill areas and surrounding vegetation management activities that could impact performance like grass clippings, etc.
- Pervious pavements can reduce winter maintenance needs. Sand should not be used for winter maintenance, and environmentally friendly deicers should be used, and only as needed. Icing rarely occurs because water infiltrates instead of ponding and freezing.
- Snow plowing should be done with care to prevent chipping of pavement. Snow piles should not be stored on the surface because they generally contain sediment and debris which will clog the system as the snow melts. (2, 13)

Planning level costs

- Moderate to high cost/acre (\$\$\$) (1)

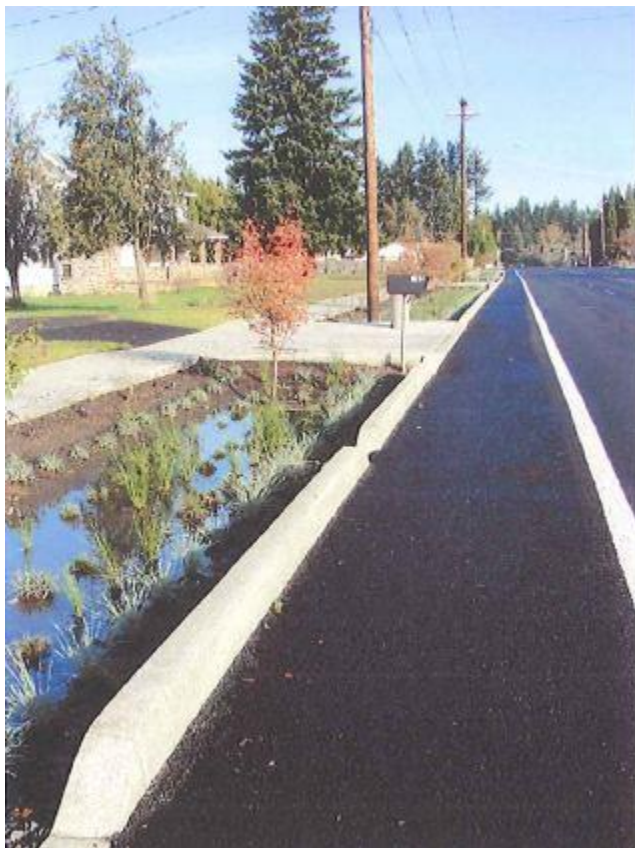

Permeable pavement is combined with bioretention systems in this example from Gresham, Oregon. (photo credit: City of Gresham, <https://www.sightline.org/2012/02/22/surprisingly-ambitious-permeable-projects/>)

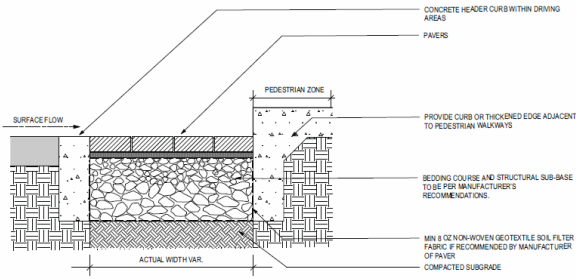

Permeable pavement design cross section (1)



Urban example of permeable pavement (1)



Rural example of permeable pavement (1)

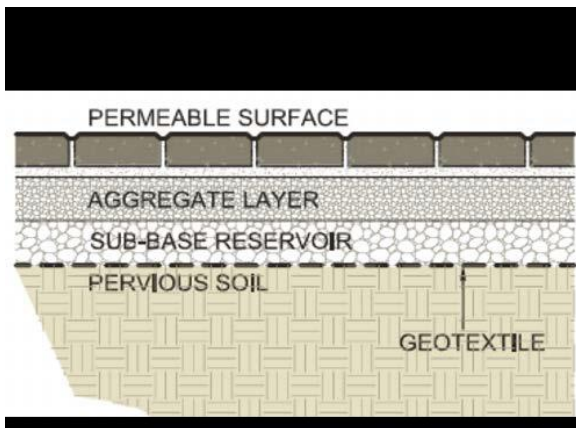

Diagram of permeable pavement (2)



Allston Way in Berkeley, California was completely renovated with permeable interlocking concrete pavers. (Photo Source: <https://www.cleanwaterprogram.org/index.php/programs/green-infrastructure/greenstreets-examples.html>)

3.1.4 Green Infrastructure Practice Sheet: Bioswales

Bioswales are broad, shallow, vegetated depressions designed to convey, treat and infiltrate stormwater runoff. They serve as both an attractive, sustainable landscaping element within a roadway setting and a stormwater infrastructure element, and they provide multiple benefits to the surrounding human and natural environment. Most importantly, they provide an opportunity to infiltrate stormwater and recharge the aquifer, reduce pollutants delivered to receiving waters, and reduce the burden of landscaping on potable water sources for irrigation. They are similar in function to bioretention systems except that they are linear and provide some conveyance of runoff. In the arid southwest, swales can be designed with a hard edge to promote linear conveyance of stormwater runoff from impervious surfaces to localized basins (1, 2). Check dams incorporated into the swale design allow water to pool and infiltrate into the underlying soil or engineered media, thus increasing the volume of water treated, especially in areas with steeper slopes (13).

Benefits

- ✓ Recharges groundwater.
- ✓ Reduces runoff rate and volume.
- ✓ Reduces pollutants/improves water quality.
- ✓ Prevents surface ponding during small rain events.
- ✓ Improves aesthetics.
- ✓ Increases habitat value.
- ✓ Provides shade/reduces urban heat island effects.
- ✓ Provides carbon sequestration.
- ✓ Improves air quality.
- ✓ Reduces long term irrigation needs/potable water dependency.

Roadway/Transportation Applications

- ✓ Roadway medians
- ✓ Rights-of-way/vegetated roadway edge
- ✓ Curb and gutter roadways
- ✓ Pedestrian/bike/multi-use paths
- ✓ 'Complete' streets for multi-modal transportation
- ✓ Parking lot islands/edges

Design Considerations

Physical Site Characteristics

- ✓ Challenging on steep slopes. Make longitudinal slope as flat as possible, and not greater than 5%. Check dams or V-weirs can be incorporated in steep-sloped settings to prevent erosion by reducing flow velocity. Check dams or weirs can also enhance treatment by increasing the volume of water retained and increasing the contact time between soil or media and runoff water.

- ✓ Consider if the site has shallow bedrock or high groundwater. Avoid groundwater contamination by separating the practice from the groundwater table. A separation distance of 3 feet is recommended between the bottom of the excavated bioretention area and the seasonally high ground water table.
- ✓ Consider using other solutions for drainage areas with gas stations, chemical storage areas, and other areas that could potentially have hazardous spills.

Design Elements

- ✓ Consider amount of nearby pedestrian activity and provide walkways or bridges across the practice if needed to allow for unimpeded movement.
- ✓ Design to avoid conflicts to subsurface utilities.
- ✓ Install appropriate erosion and flow dissipaters at the entry and exit points of the swale.

Soils

- ✓ Soils should have a suitable infiltration rate (>0.5 inches/hour). If the infiltration rate is low (<0.5 inches/hour) consider including a perforated underdrain connected to the drainage network to reduce overflows and increase safety. Other alternatives include amending soils, installing a minimum 12" sand layer under the basin, or using a dry swale with engineering media instead.
- ✓ Not suitable for highly erodible soils.
- ✓ Soils should be native or amended soils suitable to sustain the selected vegetation.

Vegetation

- ✓ Vegetation should be native, drought tolerant, salt tolerant, and able to withstand periodic inundation.

(1, 2, 8, 12, 13)

Pretreatment

- Sediment forebay, vegetated filter strips/side slopes, water quality inlets.
- Bioswales can also serve as pretreatment to a bioretention or bioinfiltration system (12, 13).

Construction considerations

- Do not over-compact basin soils, where relying on existing soils for infiltration. Compaction can reduce infiltration rates by increasing bulk density of the soil. Avoid using heavy equipment directly on bioswale soils during site preparation and construction.
- Identify appropriate materials and specify times for inspection and approval.
- During construction, avoid use sediment and erosion control measures to prevent sedimentation from upgradient construction activities to avoid clogging of the swale. When practical, complete upgradient work prior to swale installation.

(1, 13)

Maintenance

- Inspect at least annually for adequate perennial vegetation coverage, erosion and degradation of side slopes.
- Remove sediment, trash and dead vegetation at inlets and outlets to avoid clogging.
- Manage vegetation by regular weeding, pruning, removing invasive species, and revegetating as needed.
(1, 12, 13, 14)

Cost considerations

- Low to moderate cost/acre (\$\$) (1).
- Potentially less expensive installation costs than expensive curb and gutter systems (13).

3.1.5 Green Infrastructure Practice Sheet: Impervious Pavement Reduction

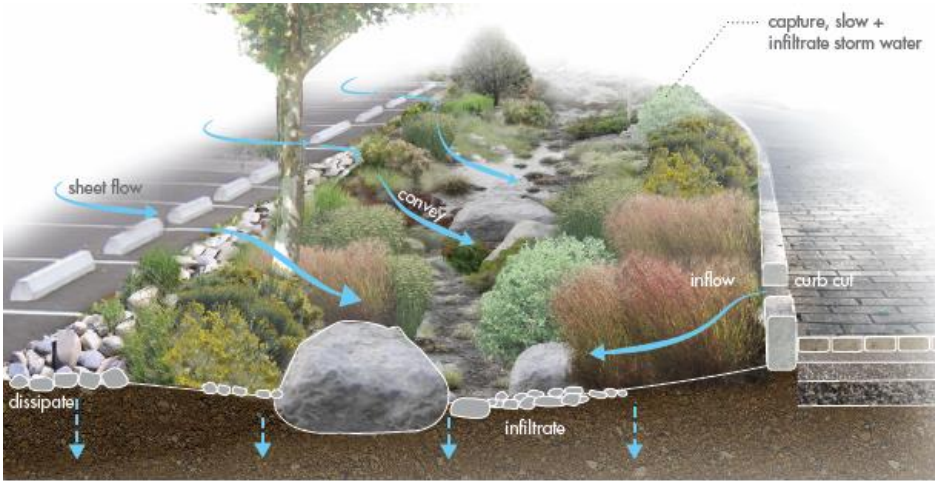

Example design of a vegetated swale/bioswale (1). Image provided by Surroundings ©.



Example of a bioswale with bioretention/bioinfiltration taking stormwater from a parking Lot (2)

Reducing the area of impervious pavement on a site, either by retrofitting an existing property or revising the initial design, reduces the volume of stormwater runoff generated at the site. It is the most effective way to preserve a site's predevelopment stormwater runoff characteristics (13). Through pavement reduction, remaining pervious areas on a site can absorb and infiltrate stormwater runoff (6, 13, 14). Impervious areas, such as roads, parking lots, building surfaces, walkways, and driveways, increase stormwater runoff volumes, and can contribute to flooding and streambank erosion (13). Impervious surfaces also facilitate the wash-off and transport of pollutants like oil, grease, nutrients, and sediment into downstream rivers, lakes and wetlands (13). A practical, simple, and cost effective tool is to identify and remove unnecessary pavement in the design phase of a new development or during the retrofit phase of a redeveloped site (13). Pavement reduction limits the size of streets, sidewalks, driveways, parking spaces, and other impervious surfaces by designing them efficiently to avoid excess unnecessary paved areas. Pavement reduction is also frequently employed for the purpose of improving roadway safety through road diets and other efforts (13). Replacement surface treatment

may include: hydroseeding, artificial turf, planting beds, washed gravel, permeable pavement/pavers, or vegetated stormwater management practices (6, 9). Impervious pavement reduction can help protect or restore the natural hydrological conditions of a site and therefore reduces the stress that is put on downstream waters.

Benefits

- ✓ Recharges groundwater.
- ✓ Reduces runoff rate and volume.
- ✓ Reduces pollutants/improves water quality.
- ✓ Improves aesthetics.
- ✓ Reduces the burden on/size of downstream stormwater management systems.
- ✓ Increases habitat value.
- ✓ Improves public safety.

Roadway/Transportation Applications

- ✓ Roadway medians
- ✓ Roundabouts
- ✓ Rights-of-way/hell strips
- ✓ Curb and gutter roadways
- ✓ Pedestrian/bike/multi-use paths
- ✓ 'Complete' streets for multi-modal transportation
- ✓ Parking lot islands/edges
- ✓ Cul-de-sacs
- ✓ Courtyards/patios

Design considerations

- ✓ Shifts excess area available for parking and travel lanes to other functions.
(14)

Right Sized Impervious Streets

- Reduce street widths and improve traffic safety where feasible by eliminating underutilized on-street parking or reducing lane width.
- Largely applicable in residential neighborhood roads.
- Local public works, police and fire departments, and residents who fear losing parking spaces and accessibility may object to narrower streets. Could also consider using permeable pavement as an alternative for parking and other areas to address this concern.
(6, 13)

Slimmer Sidewalks

- Consider if sidewalks can be installed on one side of the street or combined with multi-use paths

located in backyard easements or natural areas where suitable to meet pedestrian needs. Ensure designs comply with any Americans with Disabilities Act requirements. Whenever possible, these paths should be made of pervious materials.

- Use alternative development designs, such as cluster development, to reduce the length of roads, sidewalks, and other impervious areas. (6)

Right Sized Cul-de-sacs

- Minimize the diameter of residential street cul-de-sacs, consider hammerhead turnarounds or loop roads and/or incorporate landscaped islands. (13)

Right Sized Parking Lots

- Evaluate parking requirements considering average demand as well as peak demand.
- Consider the application of smaller parking stalls and/or compact parking spaces.
- Analyze parking lot layout to evaluate the applicability of narrowed traffic lanes and slanted parking stalls.
- Where appropriate, minimize impervious parking area by utilizing overflow parking areas constructed of pervious paving materials.
- Encourage shared parking arrangements with adjacent land uses.
- Enable owners/developers to provide proof of parking for required number of parking spaces while constructing only those that the owner/developer demonstrates are necessary. (10, 13)

Pretreatment

- Not applicable.

Construction considerations

- Not applicable.

Maintenance

- Dependent on the type of pervious surface installed.
- Examples: sweep periodically to remove accumulated debris, prune vegetation, mow turf, sweep gravel, and inspect drainage paths to ensure that adjacent conveyance structures are operable. (13)

Cost considerations

- Low cost/acre (\$), especially when incorporated into the initial design rather than removing pavement after construction.
- If the natural, pervious surface is retained during the design phase, costs are comparatively lower than if an existing impervious surface is removed and re-vegetated.



Example of Removal of Impervious Surface (1)



Pavement from underutilized parking spaces being removed in General Miles Park and replaced with rain gardens to promote infiltration. (Photo credit: Santa Fe Watershed Association)

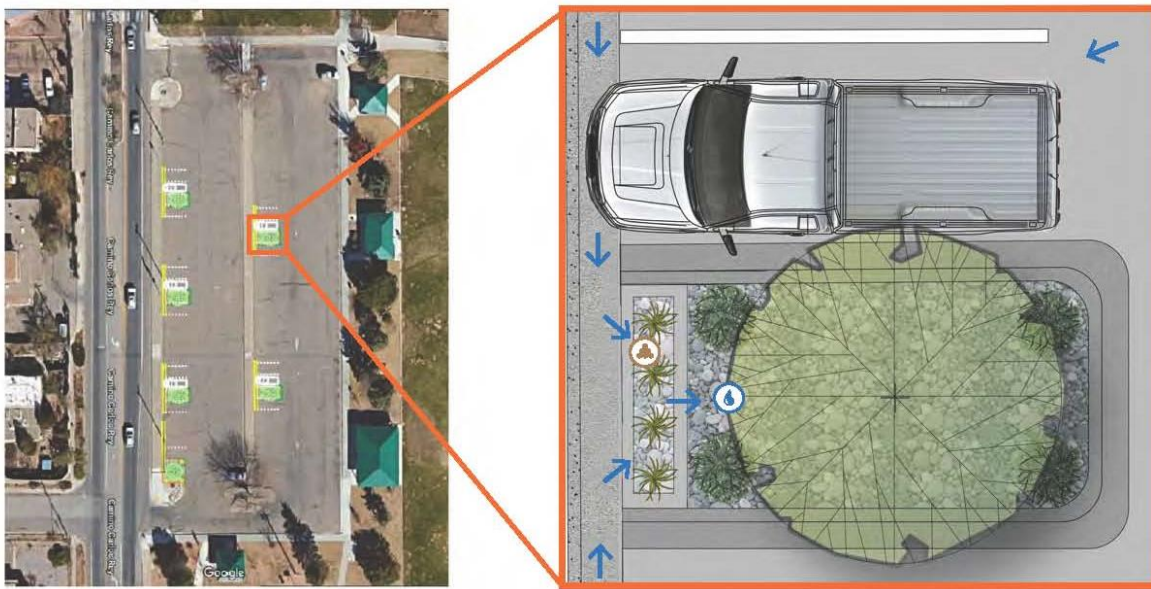

SYMBOL LEGEND

-  PRETREATMENT AREA
-  RAIN GARDEN AREA

PAVEMENT REDUCTION CONCEPT DESIGN

Pavement from underutilized parking spaces being removed in General Miles Park and replaced with rain gardens to promote infiltration. (Graphics credit: Initial concept plans were produced by Southwest Urban Hydrology for use by Santa Fe Watershed Association)

4. General Design Considerations

This section discusses opportunities and constraints to consider during site analysis and green infrastructure practice selection. The design and programmatic considerations below can be applied across green infrastructure practices, and where applicable, specific practices are referenced. Santa Fe can refer to specific design considerations, provided in the *Green Infrastructure Practice Sheets* for each practice. Factors such as water quality and other environmental benefits, the cost associated with maintenance and the city's actual ability to perform the maintenance should be considered in the selection process. The city should decide on a specific way to track these stormwater assets so that they continue to function as designed over the life cycle of the practice. There should be a clear understanding of what city department will be managing the design and implementation, and what city department will be the long-term owner and operator of the asset. Defining these responsibilities up front in the design phase will significantly increase in the likelihood of successfully implementing and maintaining green infrastructure practices over the long-term.

Soils

- ✓ Soils should have optimal infiltration rates of >0.5 inches/hour. Soil percolation tests can confirm infiltration rates. If infiltration rates are low consider amending soils, adding an underdrain or installing a minimum 12-inch sand layer under certain practices (e.g., bioretention, bioswale).
- ✓ Soils beneath structural components (e.g., footings, concrete walls, etc.) should be compacted to 90% or greater dry density. Reduce soil compaction by either mixing with soil amendments or replacing with structural soils or other suitable soil media.
- ✓ Avoid sites with highly erodible soils.
- ✓ If trees are planted as part green infrastructure practices (e.g., tree trench or trees within bioswales), suitable soil infiltration rates required to prevent tree roots from drowning, or overflow mechanism needed for larger rain events.
- ✓ For green infrastructure practices with vegetated plantings, soils should be suitable to sustain the selected plantings. In general, tree soils require more moisture holding capacity than soils that support herbaceous plants or xeriscape.
- ✓ Permeable pavement practices should carefully consider soil infiltration rates and install an overflow mechanism if needed for larger storm events.

Subcatchment Area

- ✓ Consider the drainage area to the practice. Most green infrastructure practices in Santa Fe, like tree trenches and bioretention systems, are more applicable for smaller drainage areas. For example a bioretention practice is recommended for drainage areas with less than 2 acres of impervious areas. A series of practices can be implemented in the ROW to treat larger drainage areas from major and minor arterial roads.

Site Selection and Available Space

- ✓ Avoid steep slopes.

- ✓ Evaluate if the site has shallow bedrock or high groundwater. Maintain a separation distance of 2-3 ft between the practice and the groundwater table, depending on the practice.
- ✓ Many green infrastructure practices can be incorporated in distributed, small spaces along ROWs.

Maintenance

- ✓ Prune trees and shrubs, remove dead vegetation, and remove plantings as needed to avoid overcrowding. Do not mow vegetation.
- ✓ Check for and remove invasive species.
- ✓ Remove sediment from forebays in applicable practices (e.g., bioretention). Clean out sediment and debris at inlet structures.
- ✓ If soils become compacted, turn or till soils.
- ✓ Stabilize areas to prevent erosion. Check for signs of erosion and improper root growth.
- ✓ Inspect underdrains for obstructions, if applicable.
- ✓ Permeable pavement requires regular sweeping or vacuuming and should be inspected for proper drainage as well as to identify any deterioration, cracks and settling. Inspect adjacent areas for sources of sediment, such as erosion of uphill areas. Carefully conduct vegetation management activities that could impact performance (e.g., potential clogging from grass clippings, etc.). Snow plowing should also be done with care to prevent chipping of pavement. Snow piles should not be stored on the permeable pavement surface to reduce the risk of sediment and debris clogging the pores as the snow melts.

Budget

- ✓ Budget estimates for construction and maintenance should be proposed at the concept and design phases of a project. All too often, maintenance costs are not provided or estimated, and as a result these costs are overlooked.
- ✓ Certain maintenance like pruning and trash/debris cleanout can often be done by residents, private property owners, or private sector partners. However, volunteers who help with maintenance of GI practices should be properly trained. See Section 5 for an example from Portland, Oregon on training volunteers to maintain public and private green infrastructure practices.

5. Maintenance of Green Infrastructure Practices

Green infrastructure practices are engineered systems, which require regular inspection and maintenance. Maintenance of these practices is necessary to keep components functioning as designed, and avoid expensive repairs that can result from neglect (1). As Santa Fe implements more green infrastructure practices as part of ROW projects, it may be beneficial to develop a maintenance and monitoring plan for all practices. These plans serve as a reference for engineers, designers, and planners at various stages of the project process. Once a maintenance and monitoring plan is developed, personnel can be trained on maintenance practices specific to green infrastructure – including inspection timing and maintenance schedules, costs to include during project budget development,

helpful ways to achieve maintenance goals (e.g., volunteers). It may also be worthwhile to identify departmental responsibilities for maintenance on various sites, such as parks and schools and public ROWs.

A maintenance and monitoring plan for Santa Fe may include the following components (1):

- Identify who is responsible for maintenance and monitoring.
- List the types of maintenance and monitoring activities necessary, when maintenance and monitoring should occur, and establish a checklist outlining what aspects need to be evaluated.
- Identify performance criteria for each maintenance activity.
- List the estimated annual cost for each activity identified in the Plan, including monitoring.

The maintenance and monitoring plan could be integrated with the city's overall asset management plan and tracking software. In addition, departmental procedures can be implemented to ensure that staff members follow the plan and maintenance budgets are adequate. The plan should be updated with changes in technologies and improved engineering practices. The actions listed below are programmatic in nature and would likely require approval from department heads or other decision makers.

- Ensure on-going maintenance and monitoring activities by qualified staff.
- Include maintenance and monitoring activities within the annual budget by developing estimates based upon the defined green infrastructure maintenance and monitoring plan.
- Distribute and communicate the schedules for maintenance and monitoring activities at determined locations, outlining the scope of work to be performed.
- Employees performing maintenance and monitoring provide feedback to the maintenance point of contact for unusual conditions, areas needing repairs or special maintenance.
- Integrate changes to the green infrastructure maintenance and monitoring plan based upon feedback from the field. (1)

Development of a maintenance and monitoring plan and integrating it with the asset management plan and software can help streamline the process of green infrastructure implementation in city ROW projects. It can serve as an ongoing resource to city staff and consultants so that these practices do not get lost in the shuffle. By their nature, they tend to look like traditional landscaping, but maintenance is key to maintaining their stormwater functions.

If the city implements a volunteer-based "adopt a median" or "adopt a street" program, all volunteers should be properly trained. Portland, Oregon's Green Street Stewards Program provides an effective example of such a program. As part of the Program, Portland trains volunteers to help prune vegetated plantings, remove sediment, trash, and debris from practice areas, and even add more plantings as time goes on. The graphic below illustrates city staff and volunteer maintenance responsibilities for green infrastructure practices in the ROW in Portland. (21)

<p>2-YEAR PLANT ESTABLISHMENT PHASE</p> <p>During this phase, the city or a site developer contracts with professional landscapers to care for and maintain green streets.</p> <p>The city or professional landscaper will:</p> <ul style="list-style-type: none"> ✓ Check for proper green street function ✓ Remove sediment ✓ Clear curb openings and top of overflow drain ✓ Remove trash and debris ✓ Remove weeds ✓ Water vegetation ✓ Trim trees and plants, if necessary ✓ Replace or remove trees or plants, if necessary <p>A green street steward can:</p> <ul style="list-style-type: none"> ✓ Remove trash and debris ✓ Clear curb openings and top of overflow drain ✓ Remove or push aside sediment from inlets ✓ Water vegetation during the summer or any other period of drought 	<p>LONG-TERM MAINTENANCE PHASE</p> <p>The city will monitor and maintain green street facilities, but stewards can help.</p> <p>The city will:</p> <ul style="list-style-type: none"> ✓ Check for proper green street function ✓ Remove sediment ✓ Clear curb openings and top of overflow drain ✓ Remove trash and debris ✓ Remove weeds ✓ Water vegetation, if necessary ✓ Trim trees and plants, if necessary ✓ Replace or remove trees or plants, if necessary <p>A green street steward can:</p> <ul style="list-style-type: none"> ✓ Remove trash and debris ✓ Clear curb openings and top of overflow drain ✓ Remove or push aside sediment from inlets ✓ Water vegetation during the summer or any other period of drought ✓ Remove weeds after completing a training course ✓ Add additional plants after getting written approval from Environmental Services
--	--

Figure 3. Maintenance Responsibilities - Example from Portland, OR's Green Street Stewards Program (21)

6. Permitting/Regulatory Considerations

Implementing green infrastructure in roadway settings can help Santa Fe meet municipal and state permitting requirements and regulatory goals. These include, but are not limited to: complying with the city's National Pollutant Discharge Elimination System (NPDES) Municipal Separate Storm Sewer System (MS4) permits, New Mexico Department of Transportation (NMDOT) drainage standards for roadways, landscaping requirements, and groundwater recharge or sustainability goals.

NPDES-MS4 permit. The U.S. Environmental Protection Agency (EPA) issues the New Mexico MS4 stormwater permit to prevent the discharge of harmful pollutants to waters of the United States. . Green infrastructure practices treat and manage runoff and can serve to meet permit requirements since they reduce stormwater discharges to storm sewer systems and improve water quality.

NM DOT Street Design. New Mexico's roadway and highway design standards include specific drainage requirements. Depending on the size and site considerations, GI practices can improve drainage and thereby help to meet NMDOT drainage requirements².

² NM DOT Drainage Requirements: http://dot.state.nm.us/content/dam/nmdot/Infrastructure/Drain_Design_Manual.pdf

Landscaping requirements. Landscaping is often required as part of the design of certain roadway elements, such as sidewalk bumpouts or curb extensions, green infrastructure can efficiently use public spaces, providing stormwater management functionality as well as aesthetic landscaping. Incorporating green infrastructure into landscaping can reduce irrigation needs by utilizing captured stormwater to sustain plantings.

Water resources protection. Water is a precious resource in the arid southwest. Green infrastructure practices can be designed to absorb water on site, rather than discharging runoff to the storm sewer system. At the same time, green infrastructure practices offer local flood protection benefits – capturing a percentage of runoff onsite and minimizing roadway flooding. Green infrastructure plantings can self-sustain from rainfall events, requiring minimal potable water for irrigation. This can reduce water needs and staff time and equipment for irrigation of roadside landscaping.

Drought resilience goals. Communities in arid climate regions, like Santa Fe, experience periods of prolonged drought, while at the same time experiencing isolated heavy precipitation events. Green infrastructure practices offer the ability to capture relatively large volumes of stormwater onsite and recharge groundwater supplies, meeting drought resilience goals and reducing the need for irrigation to plantings.

Sustainable Santa Fe (SSF). In its 2015 Sustainability Benchmark Report, SSF recommends that city staff collaborate with the Santa Fe Watershed Association. The Santa Fe Watershed Association is in the process of implementing strategies to achieve climate adaptation goals, including the development of a 75-year plan for a healthy urban forest that sequesters carbon, reduce the heat island, effect, absorb stormwater, control erosion, keep moisture in the local environment, and improve air quality. As mentioned in Section 1, green infrastructure practices can incorporate trees and increase tree canopy, helping the city meet a combination of these goals. (22)

7. Example Design Concepts for Santa Fe Sites

The following concept designs are examples of how the green infrastructure practices described in this guide can be integrated into various roadway settings in Santa Fe. These designs are intended to be concepts for illustrative purposes only. To facilitate familiarity with the designs, three real locations within the city were used (projects were in various stages of design at the time this guide was developed).

- Rain garden bump out at General Miles Park parking lot.
- Bioretention at the proposed Camino Entrada roundabout.
- Tree trenches at the proposed Camino Entrada roundabout.
- Tree trenches with overflows and crowned road design on Guadalupe Avenue.

DESIGN NARRATIVE

There is merit for both new development and retrofit efforts for this application. With respect to retrofitting an existing parking lot, the process begins by identifying under utilized space. Taking initiative to reduce pavement and adding multi-purpose green space improves the parks sense of place while reducing environmental impacts. For new development projects, integrating green infrastructure early in the process often results in a more successful installation. Discussing maintenance expectations and capabilities, while also using green infrastructure features as an educational amenity, or to reinforce sight lines, or even as a buffer for incompatible uses. Often times green infrastructure is value-engineered out of public improvements projects for a multitude of reasons. Including stakeholders and community members within the design process by outlining the benefits may increase the likelihood of funding beautiful, successful, and high-performing landscape features.

BENEFITS

- Reduces Under Utilized Pavement
- Provides Canopy Cover
- May Reduce Heat Island Effect
- Potential for Education
- Provides Wildlife Habitat
- Captures and Infiltrates Runoff On-site
- Straight Forward Maintenance Access
- Improves Aesthetics
- Softens Park Entrance

CONSIDERATIONS

- Ornamental grasses require additional water and care
- Cool season grasses require deep, root watering weekly
- Sediment traps should be designed for easy maintenance
- Provide sediment protection during construction
- Remove silt from surface to improve drainage

RAIN GARDEN BUMP OUT CONCEPT DESIGN



Potentilla fruticosa - Potentilla



Spiraea japonica - Spiraea 'Goldflame'



Juniperus sabina - Buffalo Juniper



Festuca ovina 'Glauc' - Blue Fescue



Calamagrostis x acutiflora - Feather Reed



Helictotrichon semperirens - Blue Oatgrass

SUGGESTED RAIN GARDEN PLANTING PALETTE



SYMBOL LEGEND

- PRETREATMENT AREA
- RAIN GARDEN AREA

PAVEMENT REDUCTION CONCEPT DESIGN

CALLOUTS

- A** PARKING / ROADWAY SURFACE
- B** CURB BORDER
- C** DROUGHT TOLERANT PLANTINGS
- D** URBAN TOLERANT TREE PLANTING
- E** STONE COVER & SANDY SOIL MEDIA

* GEOMEMBRANE LINER ON SIDEWALLS ONLY

INITIAL CONCEPT PLANS WERE PRODUCED BY:
 Southwest UrbanHydrology

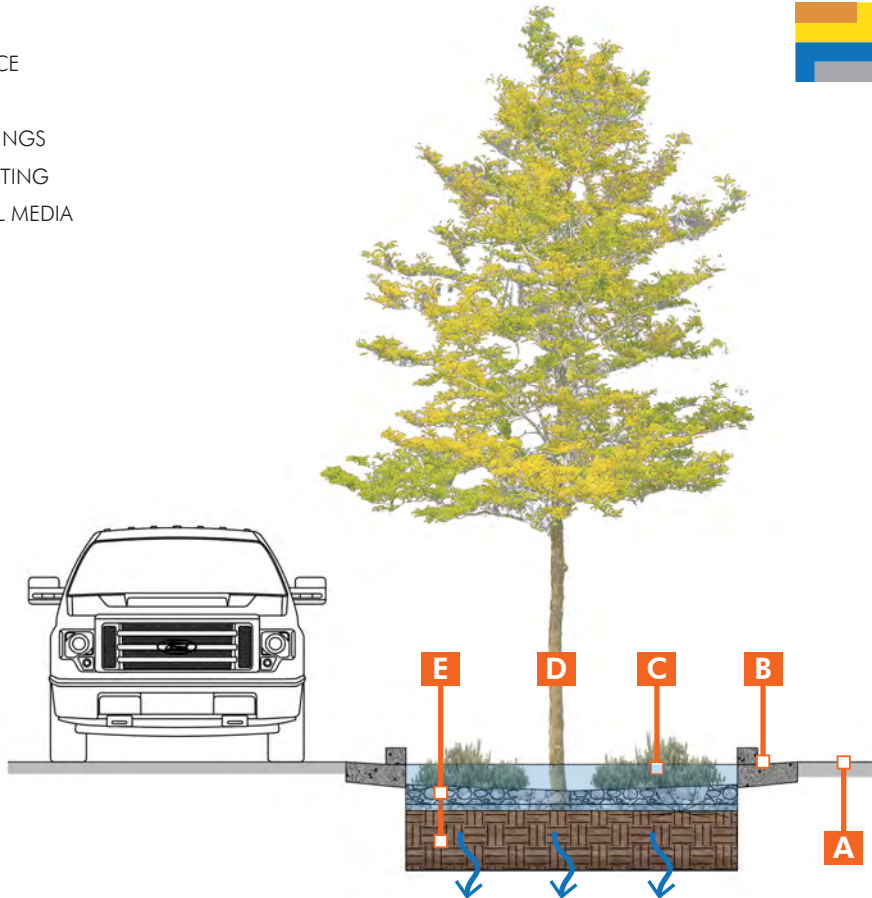

RAIN GARDEN BUMP OUT TYPICAL CONSTRUCTION DETAIL

DESIGN NARRATIVE

Locating a bioretention area within the center circle requires superelevating the roundabout inward. The current design concept illustrates three inlets, all directing runoff into sediment forebays. All three forebays are given adequate shoulder space for maintenance. The flat forebay should be designed with a hard, porous surface. A weir will detain the first flush of runoff to trap trash and debris. Runoff is then conveyed over the weir and into the bioretention area. Bioretention areas should be planted with drought tolerant, native plants which can tolerate temporary inundation. To increase public safety, this concept includes a perforated underdrain and heavy-duty overflow structure to convey excess runoff to the drainage network.

BENEFITS

- Improves Aesthetics
- Creates Wildlife Habitat
- Emergency Overflow Connections
- Lower Comparative Install Call
- Potential for Education
- Activates Under Utilized Space
- May Reduce Flooding
- Maintenance Access Via Turnout Bays
- May Provide Canopy Cover

CONSIDERATIONS

- Requires Traffic Safety Evolutions
- Higher Comparative Maintenance Cost & Effort
- Concentrates Runoff to One Location
- Cost Varies Depending on Material Selection
- May Interfere with Subsurface Utilities

BIORETENTION CONCEPT DESIGN



Nolina microcarpa - Beargrass



Nassella tenuissima - Threadgrass



Fallugia paradoxa - Apache Plume



Dasylirion wheeleri - Sotol



Ericameria nauseosa - Chamisa



Hesperaloe parviflora - Red Yucca

SUGGESTED BIORETENTION PLANTING PALETTE

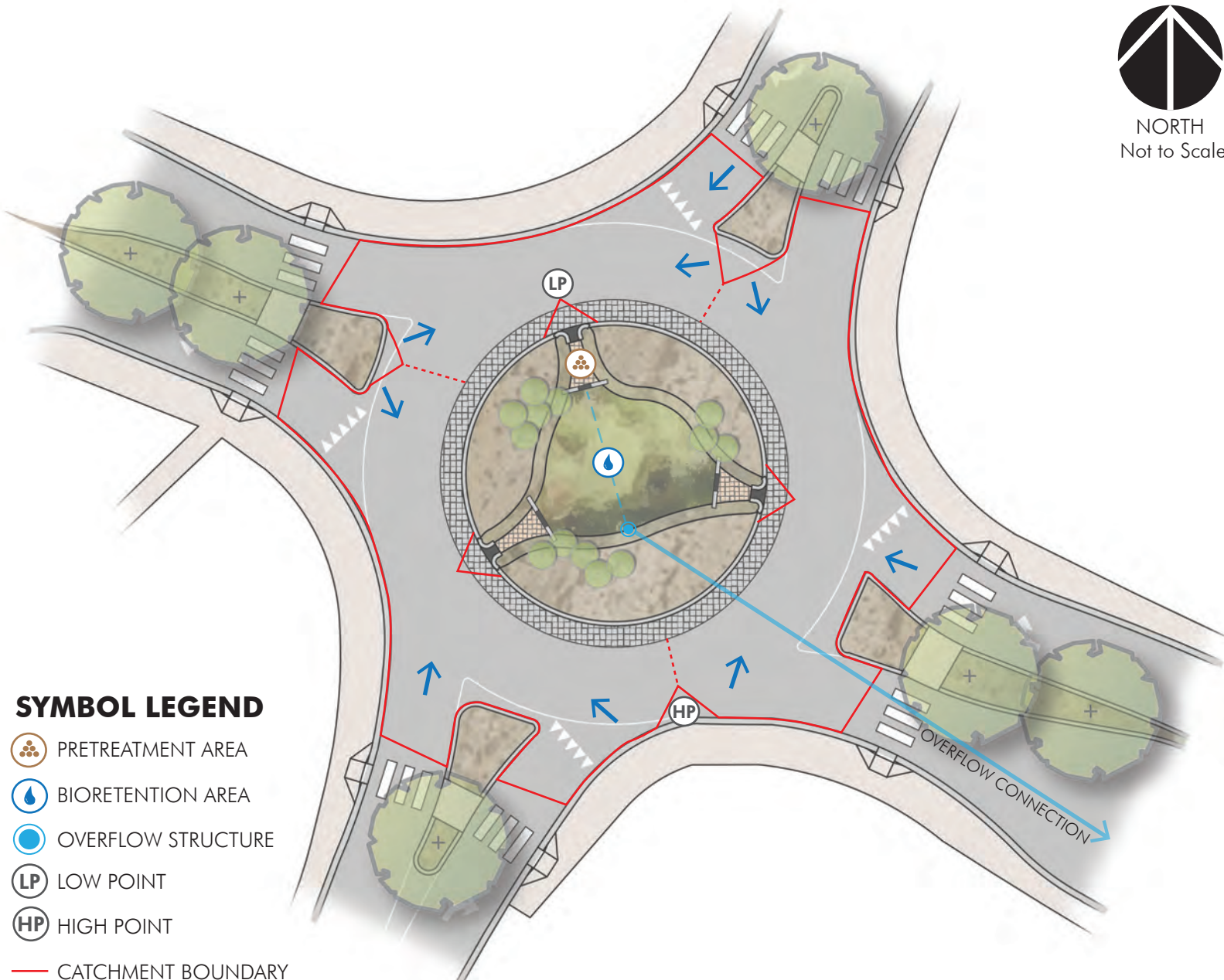

SYMBOL LEGEND

- PRETREATMENT AREA
- BIORETENTION AREA
- OVERFLOW STRUCTURE
- LOW POINT
- HIGH POINT
- CATCHMENT BOUNDARY

BIORETENTION CONCEPT DESIGN

CALLOUTS

- | | |
|--------------------------------------|-------------------------------------|
| A PERMEABLE SEDIMENT FOREBAY | E PERFORATED UNDERDRAIN |
| B WEIR & STONE SPLASH PAD | F BIOSOIL & GRAVEL RESERVOIR |
| C CLEANOUT / OBSERVATION PORT | G OVERFLOW STRUCTURE |
| D DROUGHT TOLERANT PLANTINGS | H OVERFLOW CONNECTION |

* GEOMEMBRANE LINER ON SIDEWALLS ONLY

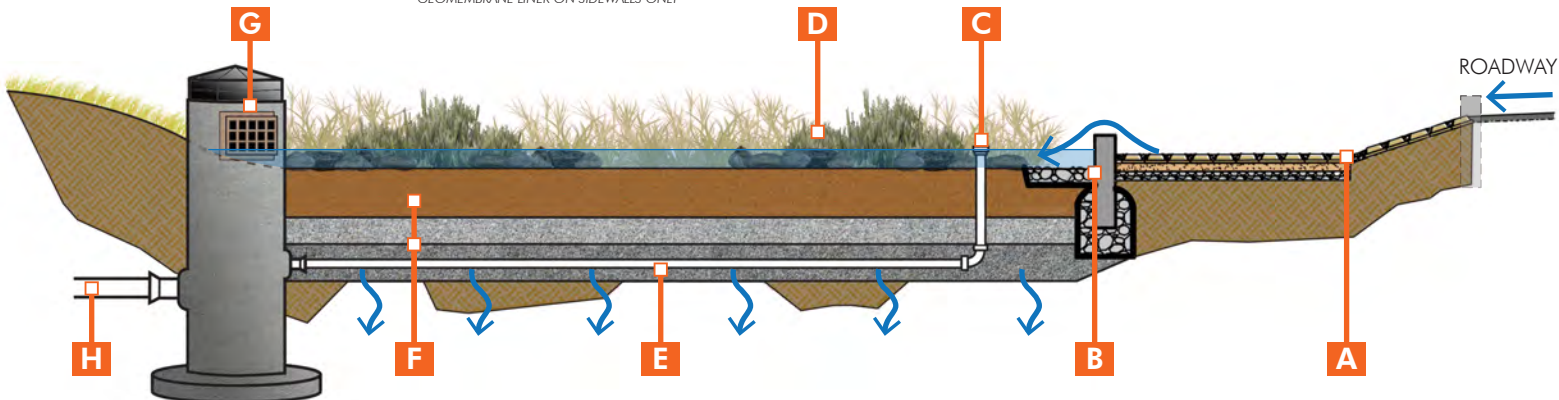

BIORETENTION TYPICAL CONSTRUCTION DETAIL

DESIGN NARRATIVE

Utilizing tree trenches encourages smaller subcatchments. This eliminates the concentration of runoff to one collection area, unlike the bioretention concept. Tree trenches require pretreatment which is graphically shown as a deep sump catchbasin. Frequent sediment cleanout is required to maintain performance. A deep sump catchbasin is a small footprint, pretreatment option. Landscape maintenance is also simplified which may include pruning, removal of dead branches, and weeding at the base. Similar to the bioretention concept, each tree trench includes a perforated underdrain for emergency overflow situations to increase public safety during extreme storm events. Small rain events will enter the trench, irrigate the root zone and infiltrate downward through the filter media.

BENEFITS

- Provides Canopy Cover
- May Reduce Heat Island Effect
- Distributes Runoff Load
- Potential for Overflow Connections
- Lower Comparative Maintenance Cost

CONSIDERATIONS

- May Impede Sight Lines
- Higher Comparative Installation Cost
- Easy Maintenance with Vector Truck
- May Interfere with Subsurface Utilities

TREE TRENCH CONCEPT DESIGN



Quercus macrocarpa - Bur Oak



Ulmus carpinifolia x parvifolia 'Frontier' - Elm



Ginkgo biloba - Maidenhair Ginkgo



Celtis occidentalis - Common Hackberry



Fraxinus americana 'Autumn Purple' - Ash



Gleditsia triacanthos - Honeylocust

SUGGESTED TREE TRENCH SPECIES

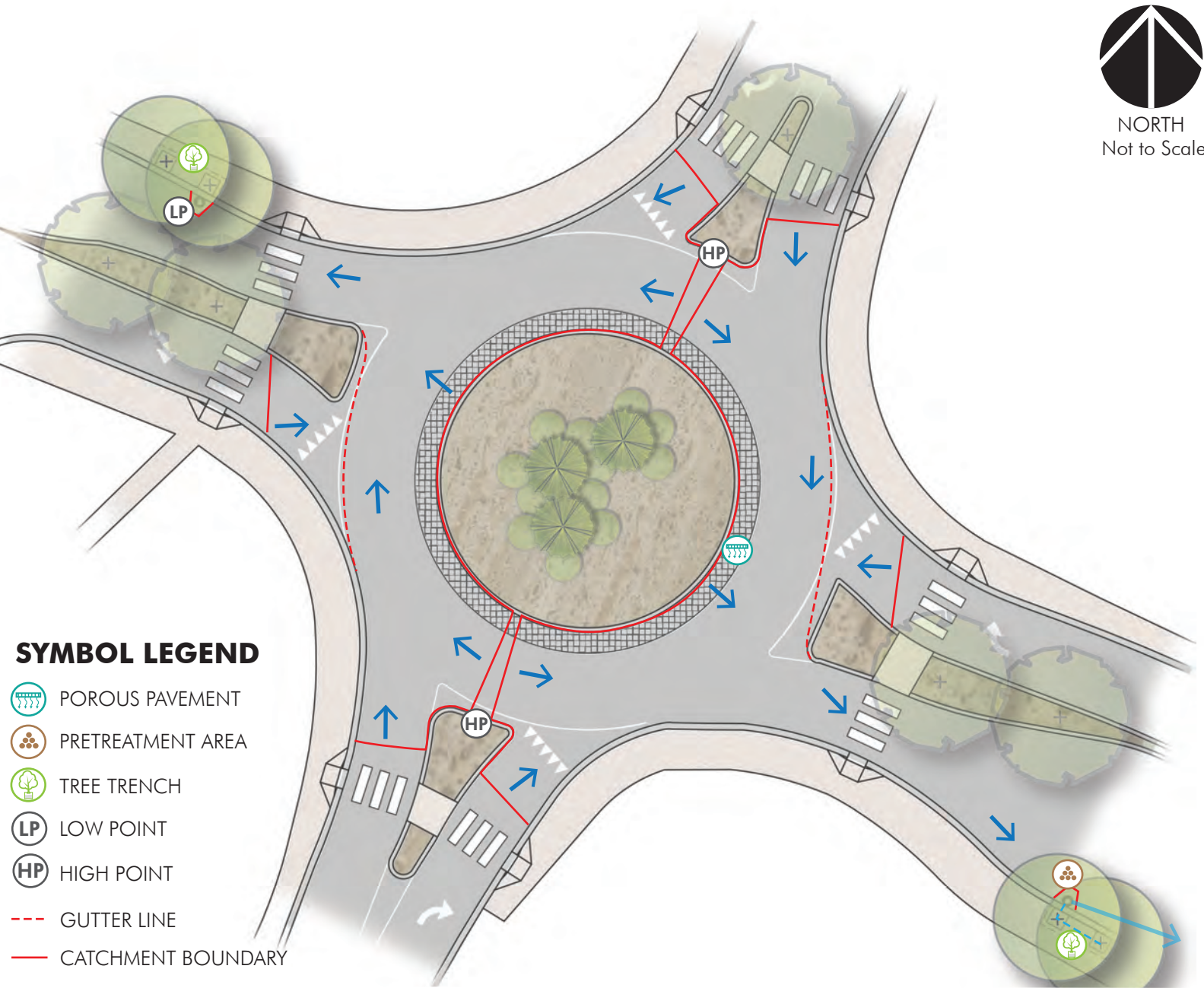

SYMBOL LEGEND

- POROUS PAVEMENT
- PRETREATMENT AREA
- TREE TRENCH
- LP
- HP
- GUTTER LINE
- CATCHMENT BOUNDARY

TREE TRENCH CONCEPT DESIGN





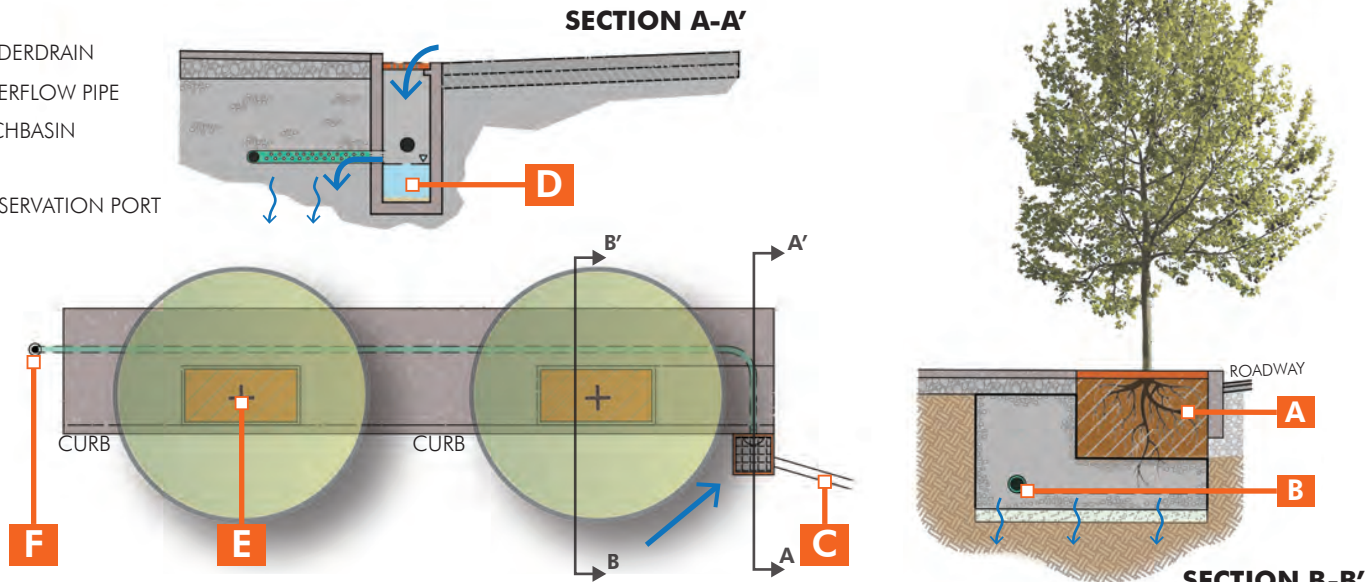

CALLOUTS

- A** TREE PIT
- B** PERFORATED UNDERDRAIN
- C** EMERGENCY OVERFLOW PIPE
- D** DEEP SUMP CATCHBASIN
- E** TREE PLANTING
- F** CLEANOUT / OBSERVATION PORT



TREE TRENCH TYPICAL CONSTRUCTION DETAIL

SYMBOL LEGEND

-  STORMWATER AREA
-  PRETREATMENT AREA
-  TREE TRENCH
-  SIDEWALK TRENCH DRAIN
-  GUTTER LINE
-  CROWNED ROAD CONTOURS
-  LOW POINT

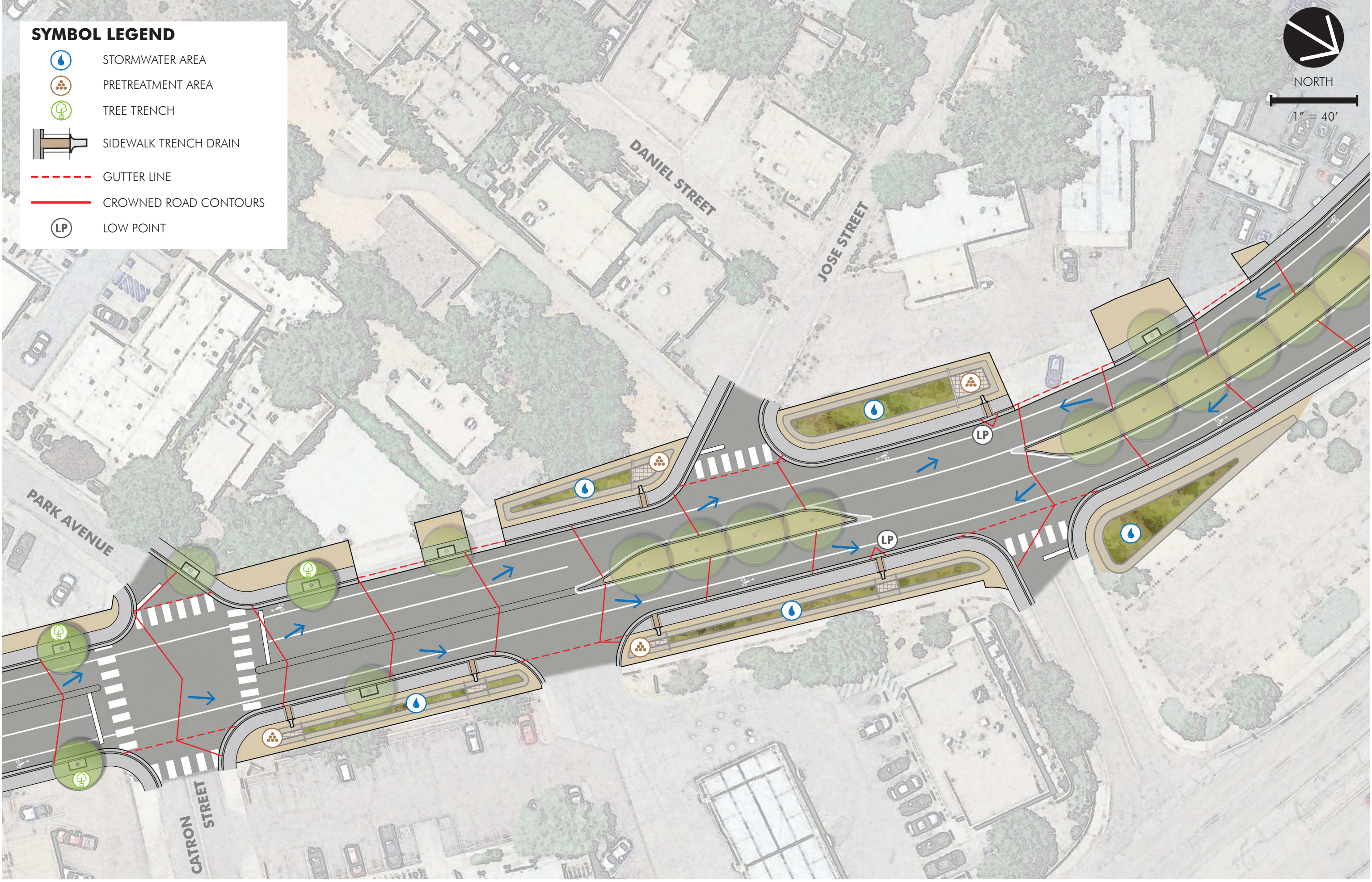

CONCEPTUAL GREEN INFRASTRUCTURE DESIGN

Initial concept design image provided by Surroundings ©

SYMBOL LEGEND

- DEEP SUMP CATCHBASIN
- OVERFLOW STRUCTURE
- DIVERSION DRAIN MANHOLE
- PERFORATED RECHARGE BASIN
- FLARED END OUTLET PIPE
- EMERGENCY OVERFLOW PIPE
- HIGH DENSITY DRAINAGE PIPE
- PERFORATED UNDERDRAIN PIPE





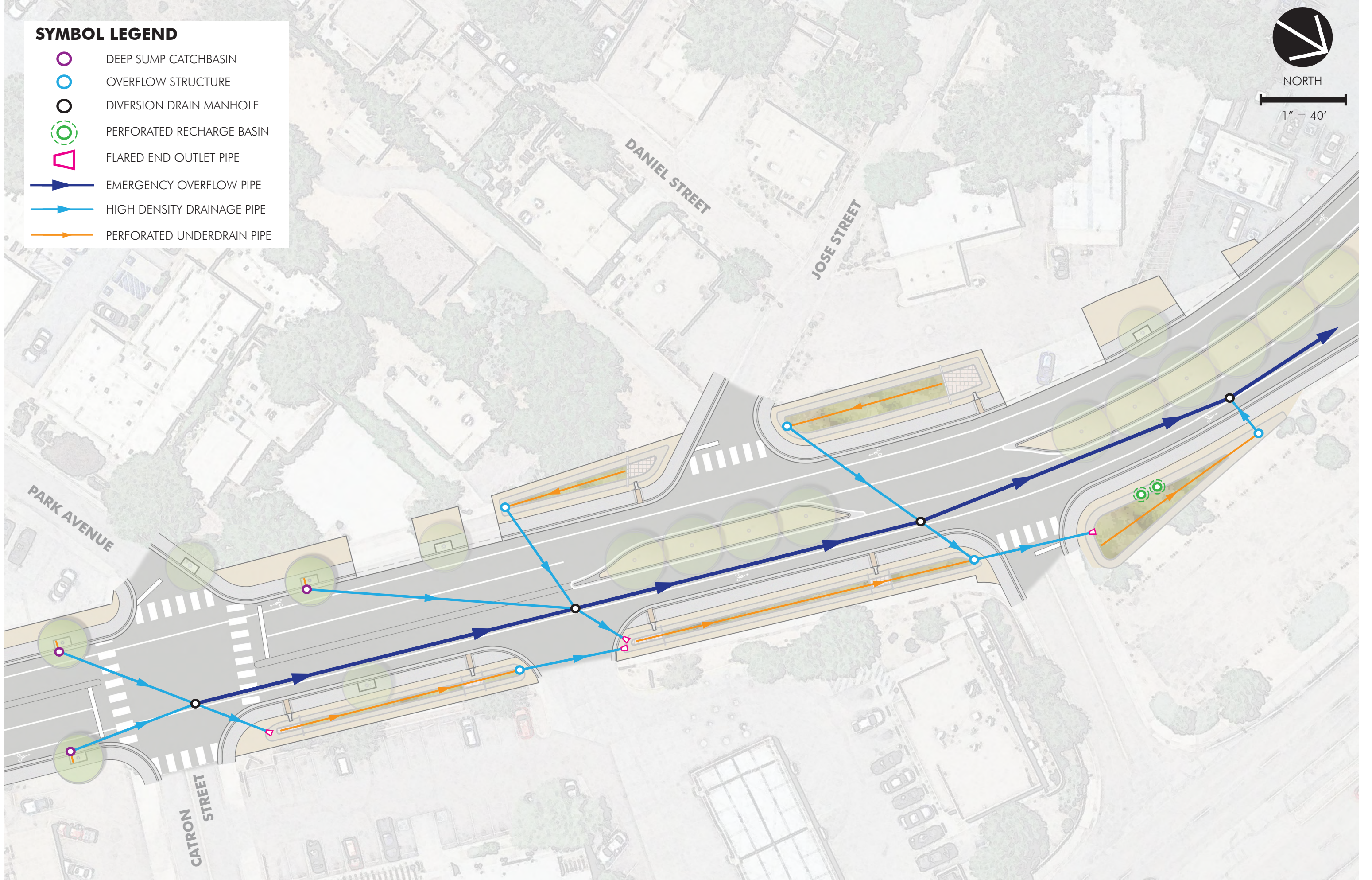

NORTH

1" = 40'



SYMBOL LEGEND

-  TREE TRENCH COLLECTION AREA
-  BIORETENTION COLLECTION AREA
-  DRAINAGE SUBCATCHMENT AREA
-  SUBCATCHMENT BOUNDARY



NORTH

1" = 40'

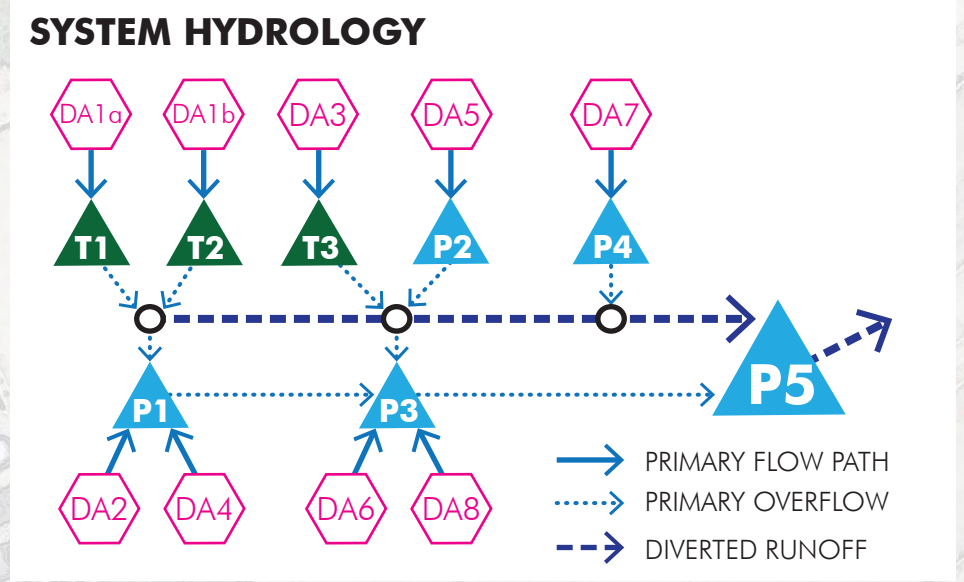
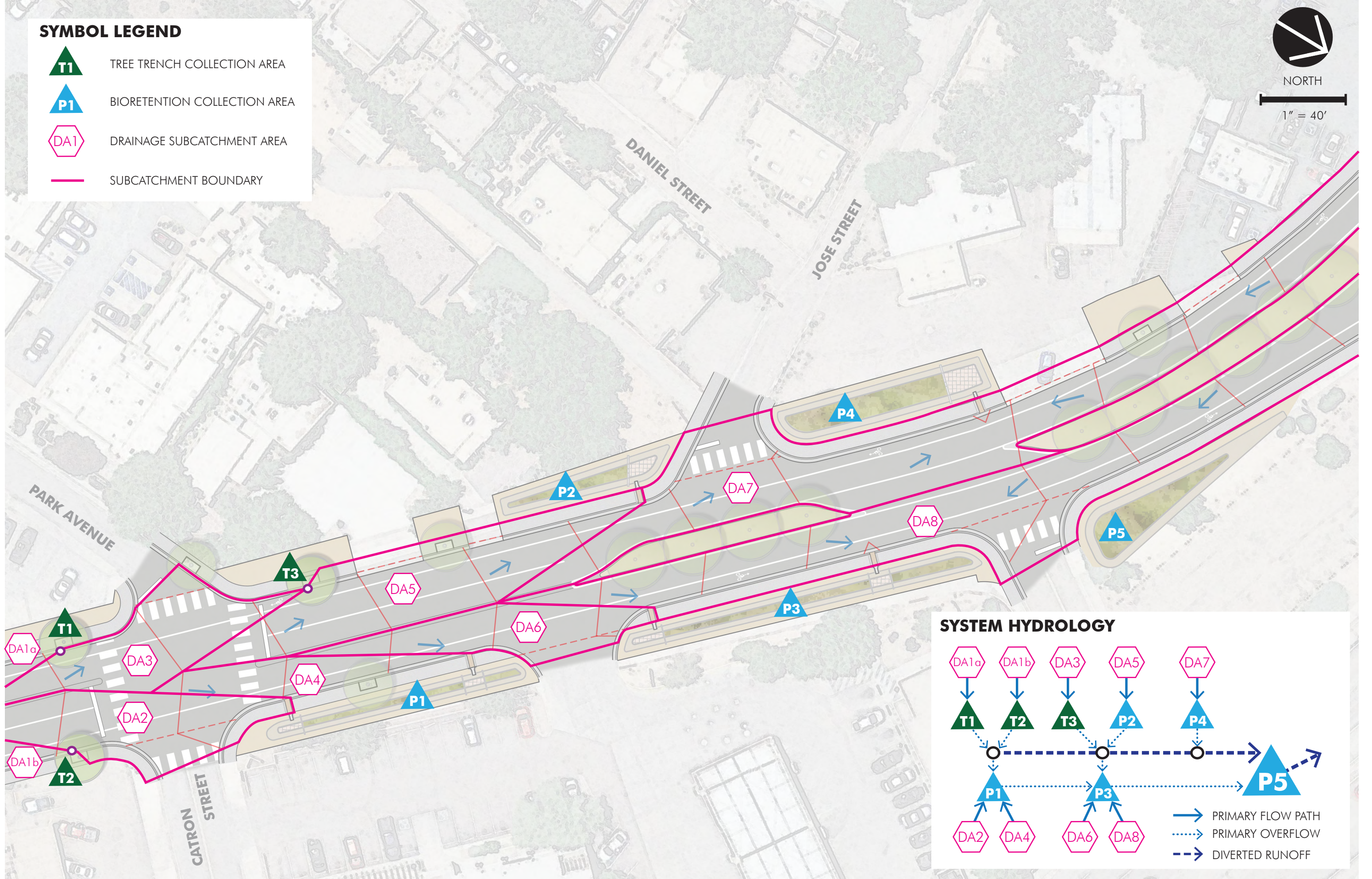

CONCEPTUAL DRAINAGE AREAS

Initial concept design image provided by Surroundings ©

8. References

This document includes a reference list with helpful documents concerning implementation of green infrastructure practices. Specific sources - especially for green infrastructure practices in arid landscapes - are referenced throughout the practice sheets. The reference list as a whole, however, can act as a guide to more in-depth research of all aspects of green infrastructure implementation.

1. Los Alamos National Laboratory Low Impact Development Standards. 2017. LA-UR-17-27538
2. Arid LID Coalition. Low Impact Development in a High Desert Climate: Green Stormwater Infrastructure Practices and Case Studies. (No Date)
3. Xeriscape Council of New Mexico. 2016. Middle Rio Grande Low Impact Development: Projects for Stormwater Management.
4. Xeriscape Council of New Mexico. 2018. Principles of Xeriscape.
5. Jiang,Y., Yuan,Y. and Piza,H.2015. A Review of Applicability and Effectiveness of Low Impact Development/Green Infrastructure Practices in Arid/Semi-Arid United States. *Environments* (2). 221-249.
6. Texas Commission on Environmental Quality. No Date. Texas Stormwater Manual Chapter 2 Non-Structural Best Management Practice.
7. City and County of Denver Public Works. 2016. Ultra-Urban Green Infrastructure Guidelines.
8. Dakota County Soil & Water Conservation District. 2017. Best Management Practices for Stormwater Quality Treatment in Urban Settings.
9. Virginia Department of Environmental Quality (VA DEQ). 2011. Stormwater Design Specification No. 7, 9.
10. Pennsylvania Department of Environmental Protection. 2006. Pennsylvania Stormwater Best Management Practices Chapter 5 Non-structural BMPs
11. EPA. 2016. Green Infrastructure and Climate Change.
12. Massachusetts Department of Environmental Protection. 2008. Massachusetts Stormwater Handbook.
13. Minnesota Pollution Control Agency. 2013. Minnesota Stormwater Manual.
14. Horsley Witten Group. 2011. EPA Region 1 MS4 Stormwater General Permits and LID Training Clinic.
<https://www3.epa.gov/region1/npdcs/stormwater/presentations/20110603FranklinDCIA.pdf>
15. Bernalillo County Green Stormwater Infrastructure – Low Impact Design Strategies for Desert Communities. No Date. Bernalillo County Commission.
16. Center for Watershed Protection. 2007. National Pollutant Removal Performance Database Version 3.
17. Minnesota Stormwater Manual, Case Studies for Tree Trenches and Tree Boxes. 2017. (Online: https://stormwater.pca.state.mn.us/index.php?title=Case_studies_for_tree_trenches_and_tree_boxes)
18. Virginia Department of Conservation and Recreation. 2013. Virginia DCR Stormwater Design Specification #9, Bioretention. Version 2.0. January 1, 2013. 59 pp.
http://chesapeakestormwater.net/wp-content/uploads/downloads/2014/03/VA_BMP_Spec_No_9_BIORETENTION_FINAL_Draft_v2-0_06Nov2013.pdf#page=2&zoom=auto,-15,736
19. University of New Hampshire Stormwater Center. 2016. UNHSC Design Specifications for Porous Asphalt Pavement and Infiltration Beds. Original Date Feb 2014, revised Dept 2016. 29 pp.
https://www.unh.edu/unhsc/sites/default/files/media/unhsc_pa_spec_-_feb-2014_-_rev_9-16.pdf

20. Tetra Tech. 2015. Estimating Predevelopment Hydrology for Urbanized Areas in New Mexico Prepared for U.S. Environmental Protection Agency Office of Wastewater Management. EPA Publication Number 832-R-15-009.
21. City of Portland Environmental Services. 2017. Green Street Stewards Maintenance Guide. <https://www.portlandoregon.gov/bes/article/319879>
22. Sustainable Santa Fe. 2015. Sustainability Benchmarks Report.